

**ARTICLE 12  
SIGNS**

**Statement of Intent**

The purpose of this article is to regulate the size, location, height and construction of all signs; to protect the public health, safety, convenience and general welfare; to facilitate the creation of a convenient, attractive, and harmonious community; to protect property values; and to further the goals, objectives and policies of the Comprehensive Plan. This article is intended to promote signs that are:

- 1) Compatible with the landscape/streetscape and architecture of surrounding buildings, and promote a favorable aesthetic quality of the Town and its unique character;
- 2) Properly designed, constructed, installed and maintained, in order to limit driver and pedestrian distraction and otherwise to promote general public safety;
- 3) Legible, relevant and appropriate to the activity to which they pertain;
- 4) Limited in size, placement and frequency, so as to provide a fair avenue for advertisement while maintaining the general value of property.

**12-1 Administration**

- A. The application and enforcement of the provisions herein shall be the responsibility of the Department of Planning & Community Development. The Director of Community Development (the Director) shall reserve the authority to designate an agent to perform these responsibilities on his/her behalf, if and where needed.
- B. The Director, or designee, shall have the authority to cause the immediate removal of any signs which are not constructed and maintained in accordance with the provisions of this Article or in accordance with the applicable provisions of the Virginia Uniform Statewide Building Code (USBC).
- C. Signs deemed unsafe shall be regulated by the following provisions, as prescribed in Va. Code § 15.2-906:
  1. Whenever in the opinion of the Director a sign becomes structurally unsafe or endangers the public safety, such sign shall be ordered to be made safe and to comply with this ordinance or removed, as the case may be. The order shall be sent by certified mail and shall be complied with within thirty (30) days from the date of receipt. Failure to comply with the order shall constitute grounds for the Director to have the sign removed, the cost of which shall be paid by the property owner.
  2. Whenever in the opinion of the Director an unsafe sign poses an imminent threat of serious injury to person or property, and it is impracticable to give notice as required by subparagraph (1), the Director may cause the sign to be immediately made safe or removed, and the cost thereof shall be paid by the property owner.
- D. In the event that special site conditions exist, such as those related to topography, building size, location, or orientation, etc., the Director shall reserve the authority to grant approval for signage so long as the subject signage meets the intent of the ordinance.

**12-2 General Provisions**

- A. *Definitions.* Definitions of various items pertaining to this Article are set forth in the *Definitions* section of this Zoning Ordinance contained in Article 20.
- B. *Applicability.* The standards, procedures, exemptions and other requirements of this article shall apply to all signs constructed, erected, moved, enlarged, illuminated, or substantially altered within the municipal limits of the Town.
- C. *Construction.* In addition to the standards set forth in this article, all signs and their structures shall conform to all applicable provisions of the USBC and all amendments thereto.

- D. *Maintenance.* All signs, and their structural and/or electrical components, shall be kept in a generally maintained state at all times.
- E. *Comprehensive Plan.* This article shall be in accordance with the Goals and Objectives of the Comprehensive Plan, notably the objective to “[i]mprove the Town’s aesthetic quality to make a positive and lasting impression on visitors to the community and enhance the quality of life for residents.”
- F. *Conflict.* In the case of conflicting regulations, the most restrictive standard shall apply.

**12-3 Permit Required for Signs**

- A. Except for signs exempted from regulation, every sign shall be constructed, erected, moved, enlarged, illuminated or substantially altered only in accordance with a sign permit issued by the Director.
- B. Prior to the issuance of any sign permit, an application for a sign permit shall be submitted to the Department of Planning and Community Development for review. The application shall be accompanied by a rendering, or “cut sheets,” of the sign face, and a scaled drawing or survey which shows the following information:
  - 1. All dimensions of the sign and its structure, if applicable.
  - 2. The area of the actual sign face
  - 3. The proposed location of the sign in reference to property lines, existing structures and other site characteristics
  - 4. Proposed manner of illumination, if applicable.
  - 5. Method of construction, if applicable, to meet the requirements of the USBC.
- C. A sign permit shall become null and void if the sign is not erected within six (6) months after the date of issuance. Upon written request and for good cause shown, one (1) six-month extension may be granted, pursuant to any required permit renewal fee.

**12-4 Signs Excluded from Regulation**

The following signs are excluded from regulation under this article:

- A. Signs of a duly constituted governmental body, such as, but not limited to, traffic, warning, directional, street, regulatory signs, Red Cross (as prescribed in Va. Code § 33.1-355), or governmental signs which are directly related to the health, safety, convenience, or welfare of the community.
- B. Signs with a total area of four (4) square feet or less, provided the signs conform to the provisions set forth in section 12-7 below and provided that multiples of such signs are not installed in a manner which resembles a larger sign.
- C. Bulletin boards, such as those commonly found at community centers, churches, and the like, as well as menu/daily special signs for eating establishments, provided they are no more than twelve (12) square feet in total area, are affixed to a building façade, are not illuminated, and only one is erected per property.
- D. Flags of the Town of Colonial Beach, Commonwealth of Virginia, United States of America, and any other flag of a government entity.
- E. Seasonal displays or decorations which do not advertise products or services.
- F. Signs not visible from a public right-of-way.
- G. Signs on a currently licensed truck, bus, or other vehicle while in the normal course of business and provided that such is not parked for display purposes.
- H. Window signs taking up no more than 30% of the total window area.

**12-5 Off-Premise Signs**

- A. Off-premise signs which only contain the business name and a directional arrow shall be permitted.
- B. The off-premise sign shall not exceed four (4) square feet in area and shall not be more than four (4) feet in height.

- C. The sign shall be located at least five (5) feet from the public right-of-way(s) and shall not interfere with any required sight triangles for property entrance(s) or adjacent roadways.
- D. A zoning permit is required for such signs.
- E. A notarized letter from the property owner(s) is to accompany the permit application indicating the property owner's permission to erect the directional sign on their property.

## 12-6 Yard Signs

- A. Yard Signs are exempt from permitting requirements and are regulated as follows:
  - 1. One (1) yard sign provided that such sign is located on the premises, is non-illuminated, and does not exceed six (6) square feet in area. Maximum sign area of the sum of all such signs shall not exceed twelve (12) square feet in total area. Yard signs shall not exceed (6) square feet in area. No more than two (2) yard signs shall be permitted on any property at one time.
  - 2. Signs shall be setback a minimum of three (3) feet from any property line(s) and shall not interfere with any required sight triangles for property entrance(s) or adjacent roadways.
  - 3. Signs shall not exceed eight (8) feet in height.
  - 4. Temporary yard signs must be temporary in nature.
  - 5. Temporary yard signs must be removed within seven (7) days of the activity in which the sign is advertising.

## 12-7 Temporary Signs

- A. In addition to the provisions set forth in Articles 12-4 and 12-7, temporary signs and banners are permitted provided such signs conform to the following provisions:
  - 1. Temporary signs and banners are subject to a zoning permit fee, as prescribed in the adopted Town Fee Schedule.
  - 2. Not more than one (1) such sign shall be located on any lot, except when such lot contains multiple establishments or uses, one (1) temporary sign or banner shall be permitted for each separately identifiable establishment or use located thereon.
  - 3. In cases where there are multiple businesses, there shall not be more than 1 temporary sign per 25-feet of road frontage with a maximum number of six (6) temporary signs
  - 4. No single temporary sign shall exceed 32 square feet in total area nor shall the sum of all temporary signs exceed 75 square feet.
  - 5. Permitted temporary signs or banners may be erected for a period of no more than thirty (30) consecutive days, and no establishment or use may erect more than
  - 6. six (6) temporary signs or banners in a calendar year.
  - 7. The temporary sign shall not be illuminated.
  - 8. The minimum setback distance shall be ten (10) feet from the right-of-way of any state primary route; this distance shall be a minimum of three (3) feet from the right-of-way of all other roadways.
  - 9. Temporary signs shall be maintained in a neat, clean and orderly fashion. Tattered and torn temporary signs shall not be permitted.
  - 10. The sign meets all other applicable provisions of this article.
  - 11. Temporary signs shall not be included in the computation of permitted sign area.
- B. In addition to the provisions set forth in Articles 12-4 and 12-7, temporary signs that flutter, rotate, or otherwise move for the purpose of attracting attention, herein referred to as fluttering signs,<sup>1</sup> are permitted provided such signs conform to the following provisions:

---

<sup>1</sup> Inflatable tube dancers, air dancers, sky dancers and similar devices are prohibited and may not be used under this ordinance.

1. Temporary fluttering signs are subject to a zoning permit fee, as prescribed in the adopted Town Fee Schedule for temporary signs and banners.
2. Not more than one (1) such sign shall be located on any lot except when such lot contains multiple establishments or uses, one (1) temporary fluttering sign shall be permitted for each separately identifiable establishment or use located thereon. The permitted fluttering signage will be allowed in addition to any permitted temporary signs or banners permitted by Section 12-7(A) above.
3. In cases where there are multiple businesses, there shall be not more than one (1) temporary fluttering sign per 25-feet of road frontage with a maximum number of six (6) temporary signs.
4. No temporary fluttering sign shall exceed a height of 10 feet.
5. Permitted temporary fluttering signs may be erected for a period of no more than thirty (30) consecutive days, and no establishment or use may erect more than six (6) temporary signs or banners in a calendar year.
6. The temporary fluttering sign shall not be illuminated.
7. The minimum setback distance shall be ten (10) feet from the right-of-way of any state primary route; this distance shall be a minimum of three (3) feet from the road right-of-way of all other roadways.
8. Temporary fluttering signs shall be maintained in a neat, clean, and orderly fashion. Tattered and torn temporary fluttering signs shall not be permitted.
9. The temporary fluttering sign meets all other applicable provisions of this article.
10. Temporary fluttering signs shall not be included in the computation of permitted sign area.

#### **12-8 Signs Prohibited**

Notwithstanding any other provision of this article, the following signs are prohibited and subject to immediate removal by the Town:

- A. Signs that flutter, rotate, or otherwise move (except for temporary signs permitted under Section 12-7(B)) for the purpose of attracting attention, or those which produce sound, odor, liquid, or visible matter such as smoke or vapor.
- B. Signs that imitate or obscure those of a duly constituted governmental body.
- C. Any sign that is displayed on a stationary motor vehicle or trailer when the vehicle or trailer is used primarily for the purpose of, and serves the function of, a portable sign
- D. Signs which advertise illegal activities under federal, state, or local laws or regulations.
- E. Signs located in any public right-of-way or attached to any utility pole or structure.
- F. Signs which are placed or located so as to impede vision or contravene other requirements of applicable traffic ordinances or statutes.
- G. Signs, not being an integral part of the building design, which are fastened to, supported by, or located on the roof of a building.
- H. Signs that extend over or above the roof line or parapet wall of a building.
- I. All other signs not expressly permitted in this ordinance.

#### **12-9 Calculation of Sign Dimensions**

- A. General Dimensional Standards:
  1. *Height.* The height of a sign shall be measured from the final grade around the sign to the highest physical point of the sign excluding supporting structure, framework, base, or bracing.

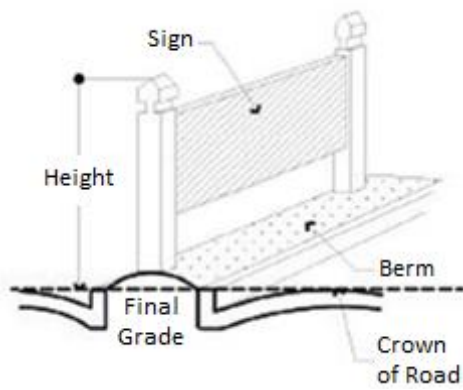

Freestanding Sign

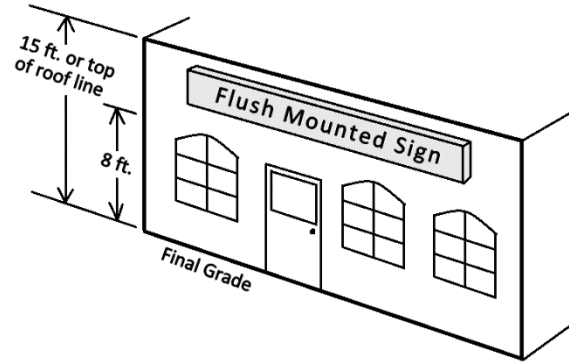

Wall Sign

2. **Area.** The area of a sign face shall be established by determining the square footage of all text, representations, colors, emblems, and other displays contained in a sign. The area shall not include any supporting structure, framework, base, or bracing.

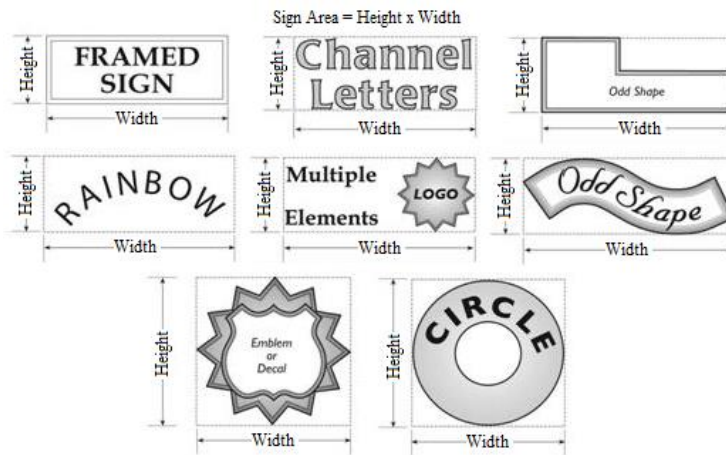

3. **Faces.** Where the sign faces of a double-faced sign are parallel, or the interior angle formed by the faces is less than 45°, only one (1) display face shall be used to compute the sign area. If the angle is greater than or equal to 45°, the area of both sign faces shall be used to compute the sign area. If the two (2) faces of a double faced sign unequal in area, the area of the larger face shall be used.

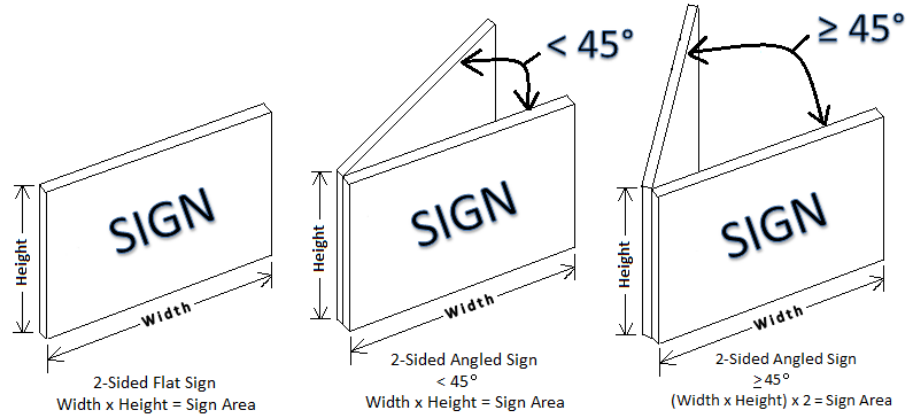

4. **Building/Lot Frontage.** A building's frontage is the horizontal length of a building on the side containing the primary entrance. If the wall is straight, then the frontage shall be the length of the wall. If the wall is not straight, the frontage shall be measured as a straight line from corner to corner of the front building face. The lot frontage is the linear distance between points where the side property lines meet the street right-of-way.

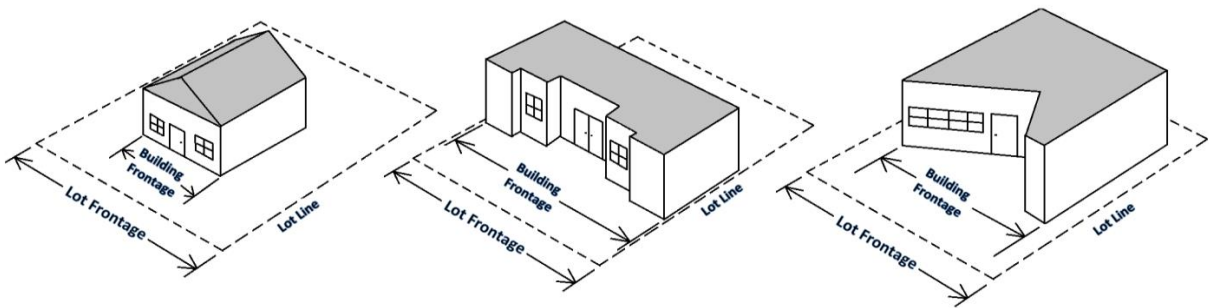

## 12-10 Sign Types

- A. **Wall Signs.** Permitted variations of wall signs include: flush mounted, suspended, marquee, canopy/awning.

### 1. General Standards.

- Such signs are permitted on the wall(s) of the building frontage which are visible from a public right-of-way.
- The area of wall sign allowed shall be one (1) square foot for every one (1) linear foot of building frontage.
- A building frontage may have up to two (2) of the permitted wall sign types, so long as the total aggregate sign area per frontage does not exceed one (1) square foot for every one (1) linear foot of building footage\_per establishment.
- On a multi-occupancy building, each occupant with a separate outside entrance to the general public may be permitted to have one (1) separate wall sign above said entrance provided the total sign area does not exceed. one (1) square foot for every one (1) linear foot of building frontage.
- Roofing elements within 30° of vertical, e.g. a "mansard" roof, may be considered a wall for the purposes of this ordinance.
- A wall sign and/or its supporting structure may project into or above a public right-of-way no more than three (3) feet, but shall not project into or over any roadway.

- g. Such signs shall be constructed of materials and in a manner that represents a finished appearance, e.g. no unfinished raw materials, exposed fasteners, unpainted surfaces or those otherwise unprotected from the elements, or any other aspect that may signify incomplete construction.

2. *Flush Mounted Wall Signs.* General standards for flush mounted wall signs are as follows:

- a. No such sign may project outward more than one (1) foot from the building façade on which it is attached.

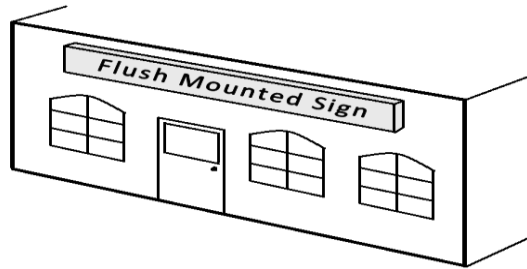

Zoning / Land Use	Flush Mounted Wall Signs			
	Permitted?	Maximum Sign area	Minimum Height	Maximum Height
R-1, R-2, R-2A, R-3, R-4*	✓	3 ft <sup>2</sup>	4 ft.	8 ft.
CR	✓	1:1**	8 ft.	15 ft.
RC	✓	1:1**	8 ft.	15 ft.
C-1, C-2	✓	1:1**	8 ft.	15 ft.
MC	✓	1:1**	8 ft.	15 ft.

\* Single-family homes are permitted one (1) wall sign only in accordance with an approved home occupation permit.

\*\* One (1) square foot for every one (1) linear foot of building footage.

3. *Projecting Wall Signs.* General standards for projecting signs are as follows:

- a. No part of any projecting sign shall be lower than eight (8) feet from final grade.
- b. No part of any projecting sign shall project farther than three (3) feet from the building façade on which it is attached.

i. *Suspended Signs.*

- a) All suspended blade signs shall be installed 90° from the building façade on which they are attached.

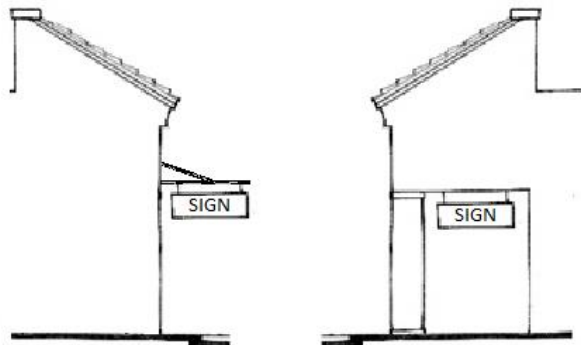

Zoning / Land Use	Suspended Signs			
	Permitted?	Maximum Sign area	Minimum Height	Maximum Height
CR	✓	15 ft <sup>2</sup>	8 ft.	15 ft.
RC	✓	15 ft <sup>2</sup>	8 ft.	15 ft.
C-1, C-2	✓	15 ft <sup>2</sup>	8 ft.	15 ft.
MC	✓	15 ft <sup>2</sup>	8 ft.	15 ft.

ii. *Marquee Signs.*

- a) All vertical marquee signs shall be installed 90° from the building façade on which it is attached.



Vertical Marquee Sign



Horizontal Marquee Sign

Zoning / Land Use	Vertical Marquee Signs				Horizontal Marquee Signs			
	Permitted?	Maximum Sign area	Minimum Height	Maximum Height	Permitted?	Maximum Sign area	Minimum Height	Maximum Height
RC	✓	15 ft <sup>2</sup>	8 ft.	15 ft.	✓	75 ft <sup>2</sup>	8 ft.	15 ft.
C-1, C-2	✓	15 ft <sup>2</sup>	8 ft.	15 ft.	✓	75 ft <sup>2</sup>	8 ft.	15 ft.

iii. *Canopy/Awning Signs.*

- a) Any lettering and/or images comprising the sign area on an awning or canopy shall be located on the face of the awning or canopy, parallel to the building.  
b) Internal illumination is not permitted on canopy/awning signs.

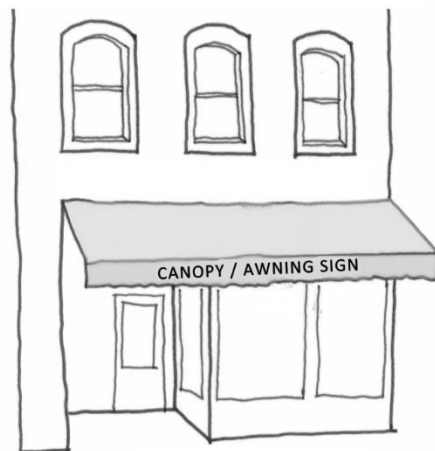

Zoning / Land Use	Canopy/Awning Signs			
	Permitted?	Maximum Sign area	Minimum Height	Maximum Height
CR	✓	15 ft <sup>2</sup>	8 ft.	15 ft.
RC	✓	15 ft <sup>2</sup>	8 ft.	15 ft.
C-1, C-2	✓	15 ft <sup>2</sup>	8 ft.	15 ft.
MC	✓	15 ft <sup>2</sup>	8 ft.	15 ft.

4. Murals (Commercial and Non-Commercial). General standards for murals are as follows:
- a. Murals shall be restricted that, by their content, threaten the public health, safety, and general welfare of the residents of Colonial Beach.
  - b. Murals shall be maintained in good repair, free from peeling paint or damage due to age.
  - c. Murals that are primarily non-commercial in nature are not subject to any size restrictions relative to the surface on which they are painted or adhered.
  - d. Murals that are primarily commercial in nature are subject to the same size restrictions as other commercial signage contained herein.
- B. *Freestanding Signs.* Permitted variations of primary freestanding signs include: double pole, hanging blade and monument. Permitted variations of secondary freestanding signs include: “a-frame” and “h-frame” as well as vertical flag signs.
1. *General Standards.*
    - a. Such signs may be double-sided, but the sides shall be identical.
    - b. The setback distance shall be a minimum of three (3) feet from the property line, except along a state primary route for which the minimum shall be five (5) ten feet, and adequate to clear sight triangles for the property entrance(s).
    - c. No part of any freestanding sign or its supporting structure may project into or above any public right-of-way.
    - d. Such signs shall be constructed of materials and in a manner that represents a finished appearance, e.g. no unfinished raw materials, exposed fasteners, unpainted surfaces or those otherwise unprotected from the elements, or any other aspect that may signify incomplete construction.
  2. *Primary Freestanding Signs.*
    - a. No property shall be permitted more than one (1) primary freestanding sign, except if the property has a secondary entrance on a separate public road. Such a property may have one (1) additional primary freestanding sign for the secondary entrance, provided that the secondary lot frontage is at least as long as the primary lot frontage.
    - b. All primary freestanding signs shall be located in a mulched and landscaped bed, exclusive of any landscaping required in Article 24 of this Ordinance.
    - c. Outparcels located in shopping centers shall not have a primary freestanding sign.
      - i. *Double Pole Signs.*

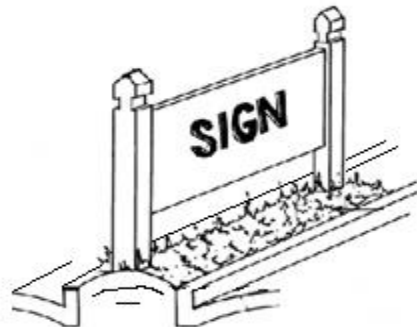

Zoning / Land Use	Double Pole Signs		
	Permitted?	Maximum Sign area	Maximum Height
Multi-Family Use*	✓	24 ft <sup>2</sup>	6 feet
Church / Institutional	✓	32 ft <sup>2</sup>	12 feet
CR	✓	32 ft <sup>2</sup>	12 feet
RC	✓	32 ft <sup>2</sup>	12 feet
C-1, C-2	✓	32 ft <sup>2</sup>	12 feet
MC	✓	32 ft <sup>2</sup>	12 feet
A-1, M-1	✓	32 ft <sup>2</sup>	12 feet

\* Such signs shall only be permitted to identify the business

ii. Hanging Blade Signs.



Zoning / Land Use	Hanging Blade Signs		
	Permitted?	Maximum Sign area	Maximum Height
Multi-Family Use*	✓	24 ft <sup>2</sup>	6 feet
Church / Institutional	✓	24 ft <sup>2</sup>	8 feet
CR	✓	24 ft <sup>2</sup>	8 feet
RC	✓	24 ft <sup>2</sup>	8 feet
C-1, C-2	✓	24 ft <sup>2</sup>	8 feet
MC	✓	24 ft <sup>2</sup>	8 feet
A-1, M-1	✓	24 ft <sup>2</sup>	8 feet

\* Such signs shall only be permitted to identify the business

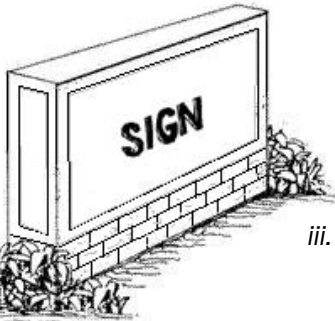

iii. Monument Signs.

- a) Such signs shall be constructed with a masonry base and/or supporting structure. The materials used shall reflect the architecture of the principal structure(s) on the property.

Zoning / Land Use	Monument Signs		
	Permitted?	Maximum Sign area	Maximum Height
Multi-Family Use	✓	32 ft <sup>2</sup>	8 feet
Major Subdivision	✓	32 ft <sup>2</sup>	8 feet
Church / Institutional	✓	32 ft <sup>2</sup>	8 feet
PUD-R	✓	64 ft <sup>2</sup>	8 feet
CR	✓	32 ft <sup>2</sup>	8 feet
RC	✓	32 ft <sup>2</sup>	8 feet
C-1, C-2*	✓	32 ft <sup>2</sup>	8 feet
MC	✓	32 ft <sup>2</sup>	8 feet
A-1, M-1	✓	32 ft <sup>2</sup>	8 feet

\* Shopping centers in these districts may have a monument sign with a max. height of 12 feet and a max sign area of 60 ft<sup>2</sup>.

3. *Secondary Freestanding Signs.* General standards for all secondary freestanding signs are as follows:

- a. An individual property may be permitted one (1) secondary freestanding sign in addition to any primary freestanding sign as specified in part d.i. below.
- b. Such signs shall be exempt from permit requirements, but shall conform to all other applicable provisions in this article.
- c. Such signs shall not be illuminated.
- d. Such signs shall be removed at the end of each business day.

i. *A-Frame & H-Frame Signs.*

- a) Each tenant within a shopping center may erect one (1) A-Frame or H-Frame sign, provided the sign is located in front of the business, does not occupy any required parking space and provides at least thirty-six (36) inches of clearance for pedestrians.

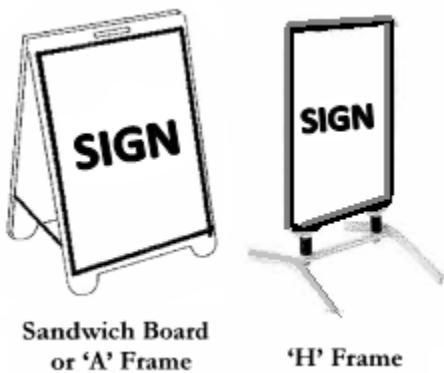

Zoning / Land Use	A-Frame & H-Frame Signs		
	Permitted?	Maximum Sign area	Maximum Height
Multi-Family Use	✓	8 ft <sup>2</sup>	4 feet
Major Subdivision	✓	8 ft <sup>2</sup>	4 feet
Church / Institutional	✓	8 ft <sup>2</sup>	4 feet
CR	✓	8 ft <sup>2</sup>	4 feet
RC	✓	8 ft <sup>2</sup>	4 feet
C-1, C-2	✓	8 ft <sup>2</sup>	4 feet
MC	✓	8 ft <sup>2</sup>	4 feet

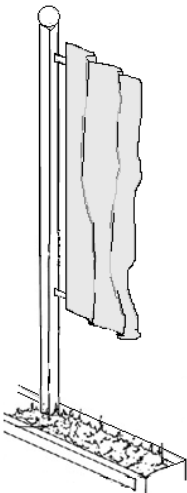

ii. *Vertical Flag Signs.*

- a) Shopping centers are permitted as provided in Section 12-7 of this article.

Zoning / Land Use	Vertical Flag Signs		
	Permitted?	Maximum Sign area	Maximum Height
CR	✓	24 ft <sup>2</sup>	12 feet
RC	✓	24 ft <sup>2</sup>	12 feet
C-1, C-2	✓	24 ft <sup>2</sup>	12 feet
MC	✓	24 ft <sup>2</sup>	12 feet

**12-11 Maximum Aggregate Sign Area**

- A. For multi-occupancy buildings and shopping centers, this maximum area shall be per business or occupant, exclusive of any respective sign area on a shared sign structure.

### **12-12 Changeable Copy Signs**

- A. Any primary freestanding sign may have up to an additional fifty (50) percent of its sign area as traditional changeable copy.
- B. Any secondary freestanding sign(s) are not permitted except as provided in Section 12-10 Section B-3, d ,i & ii.
- C. Digital changeable copy or digital billboard type signs shall be incorporated into a monument sign as specified in section 12-10, Section B-2-c-iii.

### **12-13 Sign Illumination**

- A. No flashing or intermittent illumination shall be used on any sign or structure. Scrolling text may be permitted on a digital sign in accordance with Article 12-12 above.
- B. Any sign permitted by this Article may be internally or externally illuminated, provided the illumination is installed in such a manner as to prevent the undiffused light rays from being cast upon adjacent properties, upon any public right-of-way or the night sky.
- C. Illuminated signs shall require an electrical permit in addition to a standard zoning permit.

### **12-14 Removal of Vegetation Around Signs**

- A. No person shall destroy or remove or trim any trees, shrubs or other vegetation for the purpose of increasing or enhancing the visibility of any sign if the subject vegetation is:
  - 1. Within any public right-of-way, unless the work is done by an agency having jurisdiction over such area;
  - 2. On property that is not under the ownership or control of the person responsible for such work, unless authorization is provided by the property owner where the subject vegetation is located ;
  - 3. Required landscaping, as prescribed in the *Landscaping* article of this Zoning Ordinance;
  - 4. Regulated or otherwise protected under the provisions of the *Chesapeake Bay Preservation Area Overlay District* article of this Zoning Ordinance.
- B. Limbs on the underside of any tree may be pruned, i.e. “up-limbed”, to a maximum height of twelve (12) feet in order to enhance visibility of any sign.
- C. No tree may be “topped,” i.e. have its upper limbs removed, in order to enhance visibility of any sign.

### **12-15 Nonconforming Signs**

- A. Any sign lawfully in existence on the date of enactment of this ordinance may be maintained as nonconforming until the related building occupant or use ceases operations in the space.
- B. No nonconforming sign may be enlarged or altered in such a manner as to expand the nonconformity, nor may illumination be added to any nonconforming sign.
- C. A nonconforming sign may not be moved or replaced except to bring the sign into complete conformity with this article.
- D. A nonconforming sign destroyed by any cause may not be repaired, reconstructed or replaced except in conformity with this article. For the purposes of this section, a nonconforming sign is destroyed if damaged to an extent that the cost of repairing the sign to its former condition or replacing it with an equivalent sign equals or exceeds the value of the sign so damaged.
- E. The message of a nonconforming sign may be changed so long as this does not create any new non-conformity.

### **12-16 Abandoned/Obsolete Signs**

- A. Signs advertising a business or use that have been discontinued for a period of at least two (2) years shall be deemed abandoned/obsolete. Such signs shall be brought into conformity with this Article, or removed in their entirety, as prescribed in Va. Code § 15.2-2307.